

**THOMAS ADEWUMI UNIVERSITY,
OKO, KWARA STATE.**

DEPARTMENT OF BIOLOGICAL SCIENCES



**BIOLOGICAL TECHNIQUES
(BIO 204)**

LECTURER: Oluwadamilola O. EZEKIEL

BIOLOGICAL DRAWINGS

Biological techniques include drawings because it is a method of putting on record, what you did in the laboratory. When you have studied the details of an organism, be it the external or internal structures, you want to make a diagrammatic report of what you saw. It becomes very important for the biology student to be able to make such a diagram. Your drawings should not be too small or too big, your drawings can be between a third or half a foolscap page.

While drawing,

- i. You are also expected to study the specimen taking note of proportions. For example where the length of the mango is about twice its width, your drawing must also reflect these proportions.
- ii. Record all curves.
- iii. You are not expected to shade in biological drawings.
- iv. Your pencil must be sharp. Most times you have to re-sharpen your pencil as you draw. The lines of your diagram must be thin and continuous.
- v. You should not allow the lines to go wavy or woolly. Use neat single lines.

Fig. A shows you an egg drawn with wavy and woolly lines.

Fig. B shows a clean clear drawing of the egg. Can you spot the woolly and wavy portions in the drawing 1a?

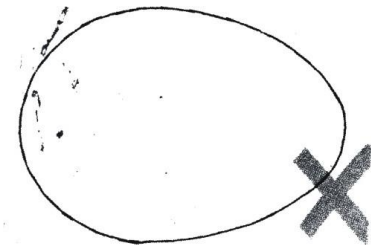

Fig. A: A poor diagram of an egg with woolly lines

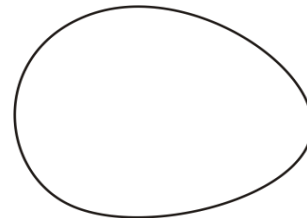

Fig. B: A clean clear diagram of an egg

- vi. You want to say how big the specimen you are presenting is in relation to your drawing. For example, you have drawn an egg and the size is exactly as it is physically. You will express this size by $\times 1$. If however you have drawn a bone. You have made your drawing half the actual size. You will express this by $\times 1/2$ (or $\times .5$). Suppose however you have drawn a bean seed which has been drawn five times bigger than it actually is, you will express this by $\times 5$.

- vii. You want to say how big the specimen you are presenting is in relation to your drawing. For example, you have drawn an egg and the size is exactly as it is physically. You will express this size by x 1. If however you have drawn a bone. You have made your drawing half the actual size. You will express this by x 1/2 (or x.5). Suppose however you have drawn a bean seed which has been drawn five times bigger than it actually is, you will express this by x 5.
- viii. You are also expected to say what aspect or view of the organism you are drawing.

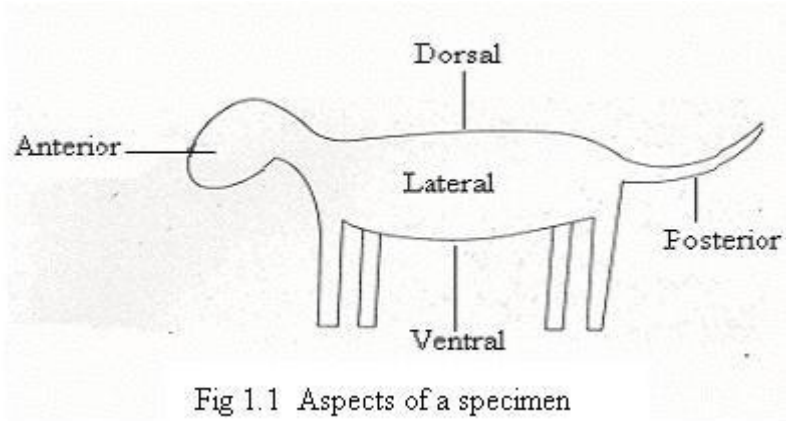

Fig 1.1 Aspects of a specimen

- ix. Sometimes, you draw what you see as you cut through your specimen to reveal internal structures. You call these sections (see figs 1.2 and 1.3)

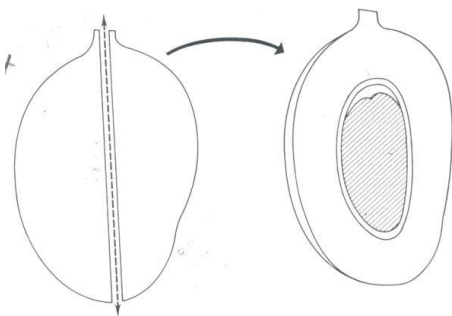

Fig. 1.2 Longitudinal section of a mango fruit(x 1)
mango fruit (x 1)

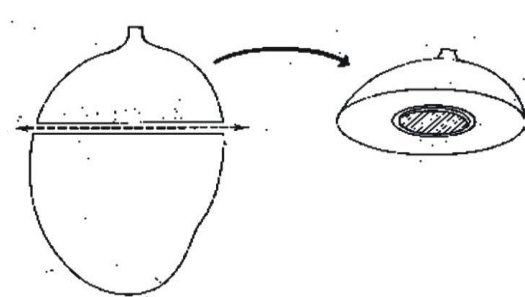

Fig 1.3 Transverse section of a mango fruit (x 1)

LABELING

An important aspect of biological drawings is the labeling lines indicating what you are labeling are called guidelines.

- The correct way to draw guideline is **horizontally** (i.e. running parallel to the top and bottom edges of your drawing paper).
- The lines should not cross each other.
- The guideline should be ruled not freely drawn with the hand.
- The guideline could be drawn on either side of the drawing if necessary, but should

not cross each other or the drawing itself.

- The shorter the guidelines, the better they are.
- Write the labels with pencil.
- No arrow at the head of the guidelines because in biology arrows show movement at direction.

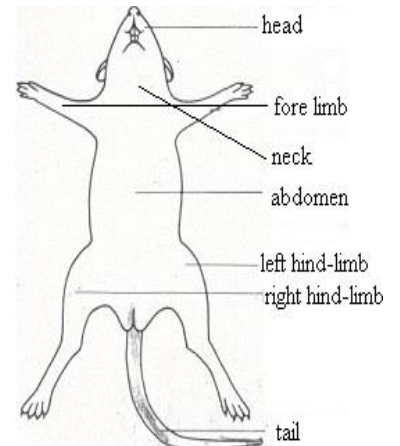
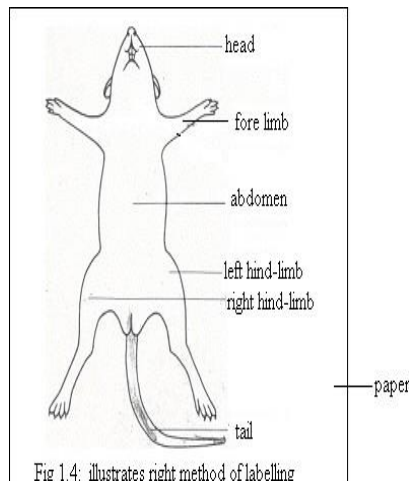

Fig. 1.4 and 1.5 show correct way to label and the incorrect way respectively.

Headings

You must put a heading for all diagrams that written above or below the diagram.

The heading contains three vital elements:

1. The identity of what you have drawn e.g. diagram of the head of a guinea pig.
2. The magnification or size.
3. The view or the organism, which you have drawn.

PREPARATION OF MICROSCOPIC SLIDES

Introduction:

The main purpose of microscope slides is to facilitate microscopic examination. Prepared slides are placed under a microscope to study tissue or cell samples and their structures at high magnification to determine whether they are normal or abnormal

TYPES OF MICROSCOPIC SLIDES

There are two main types:

1. Permanent slides: Used for long-term storage and observation.
2. Temporary slides: Used for short-term observation and teaching purposes.

Materials Needed:

- Microscope slides
- Cover slips
- Glass slide holders
- Slide trays
- Forceps
- Scalpel or razor blade
- Mounting medium (e.g., Canada balsam, DPX)
- Stains (optional)

SAMPLE PREPARATION:

1. Fixation: Preserves the sample and prevents degradation.
2. Dehydration: Removes excess water from the sample.
3. Clearing: Makes the sample transparent.
4. Staining: Enhances contrast and visibility.

PRACTICAL PROCEDURE

Step 1: Sample Preparation

1. Fixation:

- Use a fixative (e.g., formalin, ethanol) to preserve the sample.
- Follow the fixative's instructions for proper use.

2. Dehydration:

- Use a series of ethanol solutions (e.g., 30%, 50%, 70%, 90%, 100%) to dehydrate the sample.
- Start with a low concentration and gradually increase.

3. Clearing:

- Use a clearing agent (e.g., xylene, toluene) to make the sample transparent.
- Follow the clearing agent's instructions for proper use.

Step 2: Slide Preparation

1. Clean and dry the microscope slides.
2. Place a small amount of mounting medium on the slide.
3. Add the prepared sample to the mounting medium.
4. Use forceps to spread the sample evenly.

Step 3: Cover Slipping

1. Place a cover slip on top of the sample.
2. Use a scalpel or razor blade to remove excess mounting medium.
3. Seal the edges of the cover slip with a small amount of mounting medium.

Step 4: Labeling and Storage

1. Label the slide with the sample's information (e.g., name, date, stain used).
2. Store the slide in a slide tray or glass slide holder.

NOTE:

- Use a staining protocol to enhance contrast and visibility.
- Use a different mounting medium or clearing agent depending on the sample type.
- Prepare multiple slides with different stains or preparations for comparison.
- Use a microscope slide dispenser to simplify the process.

COLLECTION AND PRESERVATION OF BIOLOGICAL SPECIMENS

COLLECTION OF INSECTS

Sources: Terrestrial insects are found in gardens especially during flowering seasons, in the fields and of course indoors. Aquatic insects can be collected from water bodies like ponds, lakes etc.

Methods of collecting insects includes:

- a) net
- b) light trap, and
- c) aspiration

Methods

(a) Sweep Net Method: This method is suitable for collecting many insects.

Materials Required

Insect-collecting net and Killing jar

Steps

1. Go to the garden/field and identify the insects to be collected.
2. Approach the specimen(s) very quietly. You should try to avoid chasing the insects overtly as it would alert the insects and make them fly/run away.
3. Sweep the net (fig 6.1a) through the herbage over the specimen(s). You might have to sweep more than once.
4. When the insect(s) is trapped in the net, twist the net or your wrist so that net is closed (fig 6.1b) and the specimen is not able to escape.
5. Transfer the collected insects into the killing jar.

(b) Light Trap Method: In this method the collector is not required to be present. It is mainly used for nocturnal insects like moths, midges, some beetles and winged termites.

Materials Required

- Light sources such as an electric bulb (200 W) or a lantern lamp.
- Large shallow container such as a basin sauce pan
- White paper sheet
- Killing jar.

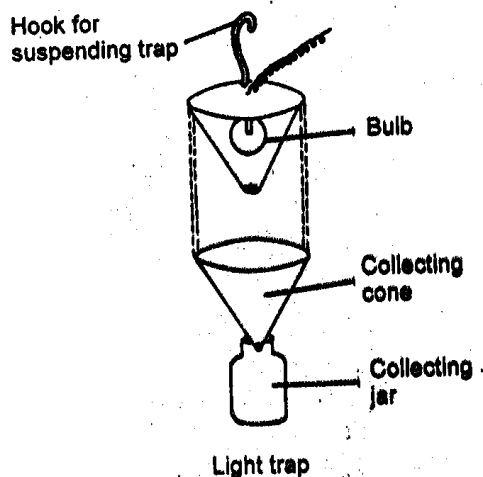

Light trap for insect collection

Selects

1. Select an area where insects are abundance
2. Hang the light source with the help of a hook.
3. Put the white paper as lining in the shallow container and set the container below the light sources so that electric lamp is shining in the middle of the container.

(In the absence of an electric light keep a lantern lamp in the middle of the container)

4. Soon the insects will be attracted by the light and fall into the container.

Note: The most efficient light source for insect trapping is a mercury vapour lamp)

5. Transfer the collected insects into the killing jar.

(c) **Aspirator:** An aspirator is a simple suction device used for collection of small insects such as mosquitoes, thrips, sandflies etc.

Materials Required

- A transparent vial made of glass or plastic (transparent plastic is preferably used).
- Rubber stopper with two holes
- Two glass tubes each with a bend Rubber tube
- Small piece of muslin cloth

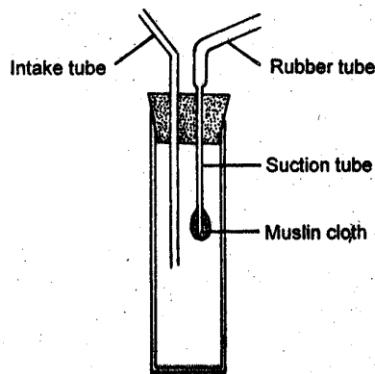

Most commonly used Aspirator

Steps

1. Insert the two glass tubes (intake and suction tube) through the two holes in the stopper.
2. At one end of one glass tube attach a rubber tube. Cover the other end of this tube by tying a piece of muslin cloth. This tube acts as a suction tube. The other tube is the intake tube.
3. To the open end of the vial fix the rubber stopper (with inserted tubes). The stopper should be tightly fixed in the vial. The end of the suction tube that is covered by muslin cloth should be inside the vial. The aspirator is now ready for use.
4. Place the aspirator with the outer end of its intake tube facing the insect(s) and suck through the rubber tube. The suction creates a partial vacuum in the vial there by drawing the insect through the intake tube. The muslin cloth tied on the inner end of suction tube will prevent the entry of insects into this tube.
5. Plug the outer end of the intake tube to prevent the escaping of the insects caught in the vial and then transfer the collected insects into the killing jar

KILLING, MOUNTING AND DISPLAY OF INSECT SPECIMENS

For killing, the insects are transferred into a bottle, containing killing agent. Through various killing agents such as ethyl acetate (safest), chloroform, ether, tetrachloroethane etc. You can make a killing bottle as given below:

Materials Required

An empty glass bottle with an air-tight lid (you can take a jam or holicks bottle)

Ethyl acetate Cotton Blotting paper Forceps

Steps

1. Soak a wad of cotton in ethyl acetate. You must hold this cotton wad with forceps and not with hands.
2. Place the soaked cotton at the bottom of the bottle and cover it with a piece of blotting paper. Blotting paper is used to avoid the direct contact of the specimens with the chemical because it will wet the specimens and spoil them. However, you can pour a few drops of killing agent over the blotting paper to make the bottle more effective. (Instead of cotton wool, plaster of paris can also be used).
3. Transfer the insects into the bottle. Close the bottle tightly. Take out the insects within 20 mins. Otherwise they will decolourise and get unduly hardened. Do not overcrowd the bottle with insects. Overcrowding of bottle with tough and fragile insects or large and small insects may cause damage to the insects. You should, therefore, use separate killing bottles for separate types of insects.
4. Label the killing bottle as 'poison' and keep it away from the reach of the others. The bottles that are no longer able to kill should be buried or burned.

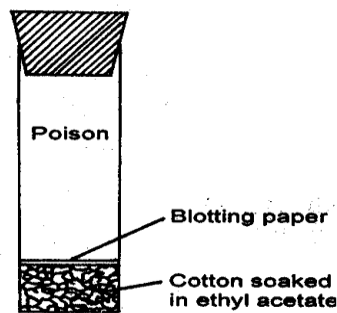

Killing bottle containing soaked ethyl acetate and blotting paper.

Mounting

Direct mounting: Mount the insects immediately after their death. Direct mounting can be done using the following steps:

1. The entomological pin is pushed through the thorax region of the insect. However, the exact point in the body of the insect through which the pin should pass differs in the different groups of insects. You can take the help of your course tutor in identifying that point in the insects you have collected.
2. Insert the pin vertically through the body or sloping in such a way that the front part of the

body is raised very slightly.

3. Push the specimen up in the pin until its back is about 1 1/2 cm away from the top. This distance helps in holding the pin freely without having any contact with the back of the insect body.
4. Mount these pinned insects on the board or on a pinning block. Take care to mount the insects uniformly so that specimens can be examined and compared easily.

Point Mounting

This method is especially used for mounting small and dried insects.

Take the following steps:

1. Take a stiff card paper and cut triangles from it. For a smaller insect the size of the triangle can be 6 mm long, 2 mm wide at base and 0.5 mm wide at the apex (tip). However, the size of the triangle varies depending upon the size of the insect.
2. Attach the dried specimens to the apical tip of the triangle with the help of a quick drying adhesive like quick-fix. The best places on the insect body for adhesion can be at the sides of thorax below the wings, margin of the tergum and above or between the bases of the legs.
3. Insert the entomological pin in the broader end of the triangle and pin this triangle with mounted insect on the display board.

Spreading

To display the head, abdomen, wings and legs you have to spread the freshly killed insects on the spreading board. In the freshly killed insects the internal parts are soft to allow the pin in and appendages are pliable. The pin is pushed through the thorax region. A spreading board is available in the market but can also be made locally. A simple method is to take a thick sheet of cork or thermocol and cut a groove in it for the body of the insect.

Steps

1. The insect is placed in such a way that the body and thorax of insect rest in the groove of the board.
2. One end of a narrow strip of setting paper is pinned at the front end on each side of the insect body.
3. The fore wings on the back are drawn forward and each pinned on either side with a fine pin inserted behind one of the strong veins in the wings.
4. The hind wings are also spread like this and pinned.
5. When the wings are correctly placed the paper strips can be taken over the wings and their other end is pinned on the back of the insect body so that both the wings are held by paper strips and setting pins.
6. The antennae are also spread symmetrically and pinned under the narrow strip.
7. Legs (appendages) are also spread and pinned on both sides under the strips. Care should be taken that while spreading, the joints and the shape of the appendages remain intact.
8. If the abdomen is inclined to fall into the groove it can be supported by crossed pins placed beneath it.

After the pinning and spreading the specimens are dried for few weeks in the open or in drying

chambers and stored.

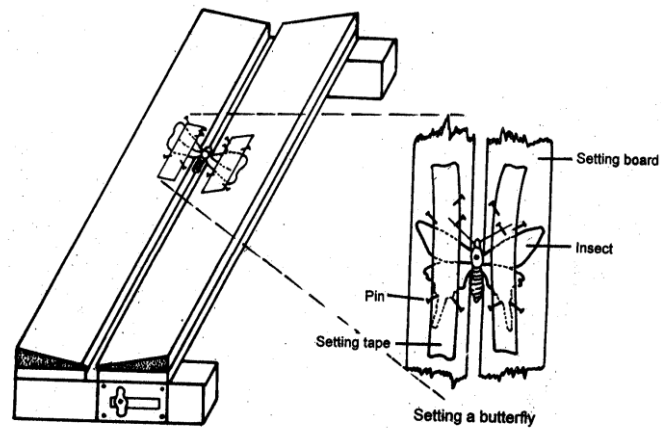

Spreading of butterfly on the spreading board. The bodyparts of the butterfly are properly spread and set on the board.

Displaying

Once the specimens are collected and spread, they should be given permanent labels. Proper mounting, spreading and displaying are necessary for taxonomic studies such as the identification and study of external morphology of the insects. These labels should be small and made of white card. The following information should be there on the label of each specimen:

1. Name of the insect.
2. Host plant, crop or the area from where it is found.
3. Locality from where it is found.
4. Date.
5. Collector's name

The ink used for writing should be permanent and not spoiled when in contact with any type of liquid.

The spread board along with spread insects with labels should be displayed in wooden boxes with glass tops. The mounted insects should also be stored in closed boxes.

You must keep naphthalene balls in the storing or displaying boxes used for insect specimens. In case these precautions are not taken the specimen insects can get spoiled or eaten by other insects/small animals.

PRESERVATION OF LIVE ANIMALS

The live animals cannot be preserved for long. The methods for keeping animals alive differ for different animals and are as follows.

The material requirements for specific animals are written beside them.

- Leeches are kept in glass containers filled with fresh water. Water should be changed everyday or on alternate days. The water used should be clean and free of dirt.
- Cockroaches are kept in a plastic or metal jar. The must have many small holes so that air is

available for their respiration. For feeding the insects small pieces of paper are put in the jar. It is advisable that fresh paper pieces are put in everyday.

- ☐Rats are kept in rat cages. For feeding they need to be given bread pieces. If the rats are to be kept for a longer period i.e few days, they should be kept in separate cages, otherwise they will hurt each other and die. Prior to dissection the rats are killed with chloroform and treated with disinfectants like phenyl, Dettol solution etc.

- ☐Frogs are kept in a sink that is covered with a wooden or plastic plank having a few holes. The water tap should be adjusted to allow the water to fall into the sink drop by drop only. This keeps the skin of the frogs moist for respiration. (In some institutions a cemented tank that has water and certain aquatic plants is built. The cover of the tank has big holes for air circulation. The frogs are kept in this tank. Here they live and breed. Within the tank area a few cemented elevations of different heights and flat top surfaces are also made. So when the frogs need to be out of the water they can jump and sit on these elevations).

HERBARIUM TECHNIQUES

What is an Herbarium? A herbarium is a collection of preserved plants stored, catalogued, and arranged systematically for scientific study by professionals and amateurs. Herbaria are a vital reference library to aid in current plant identification and future taxonomy.

A Herbarium may include some or all of the collections.

- Herbarium sheets
- Cryptogams on sheets
- Packets – cryptogams
- Lichens, fungi, fruits, seeds and related economic material (boxes of bulky specimens)
- Materia medica (jars containing dried specimens)
- Diatoms (mounted in mica on herbarium sheets or slides) and in ethanol?
- Algae (floated onto mount paper)
- Pith
- Timber (hand sections, planks, tree sections, microscopic sections)
- Pressed and bound collections
- Palm leaf materials
- Mounted slide collections
- Pollen

Methods of preparation of herbarium specimens

The preparation of a herbarium involves

- (i) Field visit
- (ii) Collection of specimens
- (iii) Drying
- (iv) Mounting on a herbarium sheet,
- (v) Preservation
- (vi) Labelling and
- (vii) Proper storage

(a) Field visits and specimen collection

A complete specimen possesses all parts including root system, flowers and fruits. Therefore, regular field visits are necessary to obtain information at every stage of growth and reproduction of a plant species. In the fields, the tools required are mainly trowel (digger) for digging roots, scissors and knife for cutting twigs, a stick with a hook for collection of parts of tall trees, a field note book, polythene bag, old newspaper and magazines.

The specimens selected should be vigorous, typical specimens. Insect-damaged plants should be avoided. Specimens should be representative of the population, but should include the range of variation of the plants. In collecting large herbs, shrubs and trees, different types of foliage, flowers and fruits should be collected from the same plant. Collect sufficient material to fill an herbarium sheet (450 x 300 mm) and still leave enough room for the label. Plants too large for a single sheet may be divided and pressed as a series of sheets Bark and wood samples are often desirable additions when collecting woody plants. There are special requirements for the identification of some plants. A Eucalyptus specimen, where possible, should include mature leaves, juvenile leaves, buds, fruits, and bark.

Other general hints for collecting are:

- 1) Bulky plants or parts can often be halved or sliced before pressing. Odd fragments - bark,

fruits or seeds - should be kept in numbered or labelled envelopes or packets with the main specimen.

2) Very bushy twigs should be pruned to make a flatter specimen, in such a way that it is obvious where pieces have been broken off.

3) Spiny plants may first be placed under a board and stood on before pressing to prevent tearing the paper.

4) Succulent plants need to be killed first by soaking in methylated spirits for 15-20 minutes. Bulbs should also be killed, or may sprout on herbarium sheet.

5) Water plants must be floated out in a dish of water and lifted out on a sheet of stiff white paper slipped under them in the water; dry excess water, then press the plant in the usual way leaving it on the white paper on which it can remain permanently stuck. A piece of waxed paper over the top of the plant will prevent it adhering to the drying paper.

6) Tall rosette plants and grasses may be pressed complete by bending them once or more into the shape of a "V", "N" or "M".

7) Dioecious plants should be represented by both sexes.

8) Palms - several herbarium sheets are necessary to show the various portions of the leaf, inflorescence and fruit of these species. Photographs of the tree and of each part are essential.

9) Cones of some gymnosperms and Pandanaceae may need to be enclosed in a wire mesh to prevent them falling apart.

b) Pressing and Care of Specimens (drying)

Specimens should be pressed as quickly as possible after collection. If this is not possible, specimens may be stored in plastic bags preferably wrapped in damp (but not wet) papers. Bags should not be packed tightly, and should be kept cool and moist. Make sure that each bag is correctly labelled for locality.

Place each specimen, with numbered tie-on tag attached, in a fold of several sheets of newspaper, and place in the press. If necessary, occasionally add a sheet of corrugated cardboard to act as a ventilator.

As you fill the press, try to keep it level to allow even distribution of pressure. This may mean the use of alternate corners of the fold for bulky roots and other parts, or packing around a bulky specimen with foam. Close the press and exert pressure with the straps. The plants in the press should be dried fairly quickly, in a warm place if possible. The specimens must not be left in damp papers or they will go moldy. It is therefore necessary to go through the press daily during the first few days and change the plants into dry newspapers.

Then continue to inspect press daily and change newspapers as necessary until the plants are dry.

Delicate plants and petals may be lost in changing and should be kept in tissue-paper (or toilet-paper) folders throughout changes. A properly dried plant specimen is brittle.

(c) Mounting:

The dried specimens are mounted on herbarium sheets of standard size (41 x 29 cm). Mounting is done with the help of glue, adhesive or cello-tape. The bulky plant parts like dry fruits seeds, cones etc. are dried without pressing and are put in small envelopes called fragment packets.

Succulent plants are not mounted on herbarium sheets but are collected in 4% formalin or FAA (Formalin Acetic Alcohol).

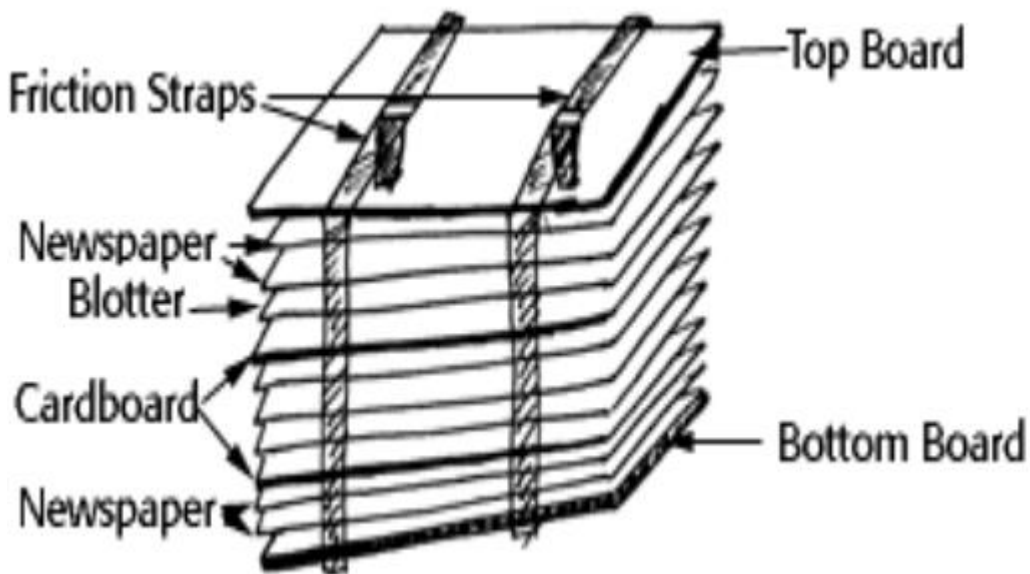

(d) Preservation

The mounted specimens are sprayed with fungicides like 2% solution of mercuric chloride.

(e) Labelling

A label is pasted or printed on the lower right hand corner. The label should indicate the information about the locality, altitude, habit, date and time of collection, name of collector, common name, complete scientific name etc.

The collection is also recorded in the field notebook together with information about that collection. As much as possible of the following data should be included:

Exact locality - a good plain language description, and latitude and longitude.

Altitude.

Nature of the habitat - type of soil, topography, slope, aspect. Associated species, vegetation type.

The plant proper - record features which will not be evident from the pressed specimen e.g. whether it is a tree or shrub, height, branching, notes on root system, odour, etc., as well as those features which may be lost on drying e.g. flower colour and odour.

Name: _____
(who collected the plant specimen)

Date: _____

Location: _____

Common Name: _____

Scientific Name: _____

 <http://askabiologist.asu.edu/activities/create-your-own-herbarium>

f) Storage

Properly dried, pressed and identified plant specimens are placed in thin paper folds (specimen covers) which are kept together in thicker paper folders (genus covers), and finally they are incorporated into the herbarium cupboards in their proper position according to a well known system of classification

CHROMATOGRAPHY

Chromatography is a laboratory technique used to separate, identify, and purify components of a mixture. Chromatography is a Greek word meaning "color writing". Developed by Mikhail Tsvett in 1906. It separates components based on differences in affinity for a stationary phase and a mobile phase.

TYPES OF CHROMATOGRAPHY

1. Liquid Chromatography (LC)
 - Mobile phase is a liquid
 - Stationary phase is a solid or liquid
2. Gas Chromatography (GC)
 - Mobile phase is a gas
 - Stationary phase is a solid or liquid
3. Thin-Layer Chromatography (TLC)
 - Mobile phase is a liquid
 - Stationary phase is a thin layer of solid
4. Paper Chromatography
 - Mobile phase is a liquid
 - Stationary phase is a paper
5. Ion-Exchange Chromatography
 - Separates ions based on charge
6. Size-Exclusion Chromatography
 - Separates molecules based on size
7. Affinity Chromatography
 - Separates molecules based on specific interactions

CHROMATOGRAPHY PROCESS

1. Sample Preparation
 - Dissolve the sample in a solvent
 - Filter or centrifuge the sample
2. Stationary Phase Preparation
 - Prepare the stationary phase material
 - Pack the stationary phase into a column or plate
3. Mobile Phase Preparation
 - Choose a mobile phase solvent
 - Prepare the mobile phase
4. Chromatography Run
 - Introduce the sample into the stationary phase
 - Introduce the mobile phase
 - Allow the mobile phase to flow through the stationary phase
5. Detection and Analysis
 - Detect the separated components
 - Analyze the chromatogram

TERMINOLOGIES IN CHROMATOGRAPHY TECHNIQUES

- Retention Factor (Rf): Distance traveled by a component divided by distance traveled by the mobile phase
- Retention Time: Time taken by a component to travel through the column
- Chromatogram: Visual representation of the separated components
- Peak: Representation of a component in the chromatogram

APPLICATIONS OF CHROMATOGRAPHY

1. Analytical Chemistry: To Identify and quantify components of a mixture
2. Purification: To Separate and purify components of a mixture
3. Biochemistry: To Separate and analyze biomolecules
4. Pharmaceuticals: To Analyze and purify drugs
5. Environmental Science: To Analyze and separate environmental pollutants

ADVANTAGES OF CHROMATOGRAPHY PROCESS

1. High resolution and sensitivity
2. Can separate and analyze complex mixtures
3. Can be used for both analytical and preparative purposes

LIMITATIONS OF CHROMATOGRAPHY

1. Requires specialized equipment and expertise
2. Can be time-consuming and labor-intensive
3. May not be suitable for all types of samples

4. CALORIMETRY

5. Calorimetry is the scientific study of heat transfer and energy exchange between systems. It involves the measurement of heat flow, energy transfer, and temperature changes in various processes, such as chemical reactions, phase transitions, and physical transformations. Here's a detailed note on calorimetry:

6. TYPES OF CALORIMETRY

7. 1. Adiabatic Calorimetry: Measures heat transfer without any heat exchange with the surroundings.
8. 2. Isothermic Calorimetry: Measures heat transfer at a constant temperature.
9. 3. Differential Scanning Calorimetry (DSC): Measures heat flow differences between a sample and a reference material.
10. 4. Bomb Calorimetry: Measures the heat of combustion of a substance.
11. 5. Reaction Calorimetry: Measures the heat evolved or absorbed during a chemical reaction.

12. TYPES OF CALORIMETER

13. 1. Bomb Calorimeter: A sealed vessel used to measure the heat of combustion.
14. 2. Coffee Cup Calorimeter: A simple, adiabatic calorimeter used to measure heat transfer.
15. 3. Differential Scanning Calorimeter (DSC): An instrument used to measure heat flow differences.
16. 4. Reaction Calorimeter: A device used to measure the heat evolved or absorbed during a

chemical reaction.

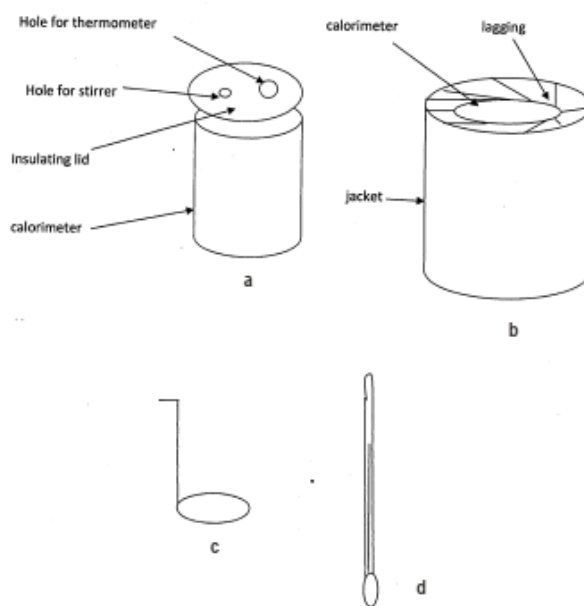

Fig 3.1:a, a calorimeter; b, a lagged calorimeter; c, a stirrer and d, a thermometer

17.

18.

19.

20. APPLICATIONS OF CALORIMETRY

21. 1. Chemistry: Studying chemical reactions, thermodynamics, and kinetics.

22. 2. Materials Science: Analyzing phase transitions, thermal stability, and energy storage.

23. 3. Biology: Investigating metabolic pathways, enzyme kinetics, and bioenergetics.

24. 4. Food Science: Measuring heat transfer, thermal properties, and food safety.

25. 5. Pharmaceuticals: Determining drug stability, purity, and bioavailability.

26.

27. KEY CONCEPTS IN CALORIMETRY

28. 1. Heat Capacity: The amount of heat required to change the temperature of a substance.

29. 2. Enthalpy: A measure of the total energy of a system.

30. 3. Entropy: A measure of disorder or randomness in a system.

31. 4. Heat Flow: The transfer of energy from one body to another due to a temperature difference.

32. CALORIMETRY EQUATIONS

33. 1. $Q = mc\Delta T$: Heat transfer (Q) equals mass (m) times specific heat capacity (c) times temperature change (ΔT).

34. 2. $\Delta H = Q$: Enthalpy change (ΔH) equals heat transfer (Q).

35. 3. $\Delta S = Q/T$: Entropy change (ΔS) equals heat transfer (Q) divided by temperature (T).

36.

37. Calorimetry is a fundamental tool for understanding energy transfer and thermodynamic processes in various fields, enabling researchers to measure and analyze heat flow, energy changes, and temperature variations with high accuracy.

PHOTOMETRY

A **photometer** is an instrument that measures the strength of electromagnetic radiation in the range from ultraviolet to infrared and including the visible spectrum. Most photometers convert light into an electric current using a photoresistor, photodiode, or photomultiplier.

Photometers measure:

- Illuminance
- Irradiance
- Light absorption
- Scattering of light
- Reflection of light
- Fluorescence
- Phosphorescence
- Luminescence

Photometry was done by estimation, comparing the luminous flux of a source with a standard source. By the 19th century, common photometers included Rumford's photometer, which compared the depths of shadows cast by different light sources, and Ritchie's photometer, which relied on equal illumination of surfaces. Another type was based on the extinction of shadows.

Modern photometers utilize photoresistors, photodiodes or photomultipliers to detect light. Some models employ photon counting, measuring light by counting individual photons. They are especially useful in areas where the irradiance is low. Photometers have wide-ranging applications including photography, where they determine the correct exposure, and science, where they are used in absorption spectroscopy to calculate the concentration of substances in a solution, infrared spectroscopy to study the structure of substances, and atomic absorption spectroscopy to determine the concentration of metals in a solution.

History

Before electronic light sensitive elements were developed, photometry was done by estimation by the eye. The relative luminous flux of a source was compared with a standard source. The photometer is placed such that the illuminance from the source being investigated is equal to the standard source, as the human eye can judge equal illuminance. The relative luminous fluxes can then be calculated as the illuminance decreases proportionally to the inverse square of distance. A standard example of such a photometer consists of a piece of paper with an oil spot on it that makes the paper slightly more transparent. When the spot is not visible from either side, the illuminance from the two sides is equal.

By 1861, three types were in common use.^[1] These were Rumford's photometer, Ritchie's photometer, and photometers that used the extinction of shadows, which was considered to be the most precise.

Rumford's photometer

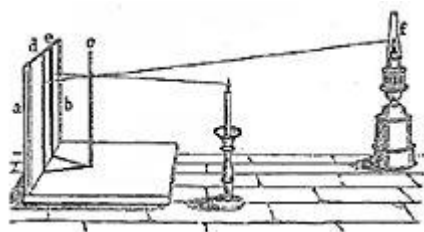

Rumford's photometer

Rumford's photometer (also called a shadow photometer) depended on the principle that a brighter light would cast a deeper shadow. The two lights to be compared were used to cast a shadow onto paper. If the shadows were of the same depth, the difference in distance of the lights would indicate the difference in intensity (e.g. a light twice as far would be four times the intensity).

Ritchie's photometer

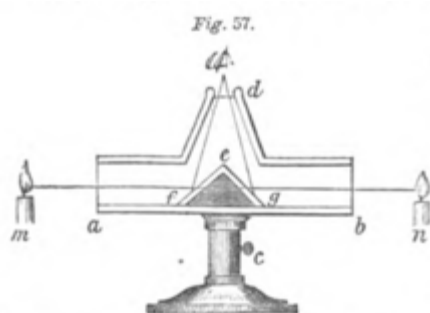

Ritchie's photometer

Ritchie's photometer depends upon equal illumination of surfaces. It consists of a box (a,b) six or eight inches long, and one in width and depth. In the middle, a wedge of wood (f,e,g) was angled upwards and covered with white paper. The user's eye looked through a tube (d) at the top of a box. The height of the apparatus was also adjustable via the stand (c). The lights to compare were placed at the side of the box (m, n)—which illuminated the paper surfaces so that the eye saw both surfaces at once. By changing the position of the lights, they were made to illuminate both surfaces equally, with the difference in intensity corresponding to the square of the difference in distance.

Method of extinction of shadows

This type of photometer depended on the fact that if a light throws the shadow of an opaque object onto a white screen, there is a certain distance that, if a second light is brought there, obliterates all traces of the shadow.

Principle of photometers

Most photometers detect the light with photoresistors, photodiodes or photomultipliers. To analyze the light, the photometer may measure the light after it has passed through a filter or through a monochromator for determination at defined wavelengths or for analysis of the spectral distribution of the light.

Photon counting

Some photometers measure light by counting individual photons rather than incoming flux. The operating principles are the same but the results are given in units such as photons/cm² or photons·cm⁻²·sr⁻¹ rather than W/cm² or W·cm⁻²·sr⁻¹.

Due to their individual photon counting nature, these instruments are limited to observations

where the irradiance is low. The irradiance is limited by the time resolution of its associated detector readout electronics. With current technology this is in the megahertz range. The maximum irradiance is also limited by the throughput and gain parameters of the detector itself.

The light sensing element in photon counting devices in NIR, visible and ultraviolet wavelengths is a photomultiplier to achieve sufficient sensitivity.

In airborne and space-based remote sensing such photon counters are used at the upper reaches of the electromagnetic spectrum such as the X-ray to far ultraviolet. This is usually due to the lower radiant intensity of the objects being measured as well as the difficulty of measuring light at higher energies using its particle-like nature as compared to the wavelike nature of light at lower frequencies. Conversely, radiometers are typically used for remote sensing from the visible, infrared through radio frequency range.

PHOTOGRAPHY

Photometers are used to determine the correct exposure in photography. In modern cameras, the photometer is usually built in. As the illumination of different parts of the picture varies, advanced photometers measure the light intensity in different parts of the potential picture and use an algorithm to determine the most suitable exposure for the final picture, adapting the algorithm to the type of picture intended (see Metering mode). Historically, a photometer was separate from the camera and known as an exposure meter. The advanced photometers then could be used either to measure the light from the potential picture as a whole, to measure from elements of the picture to ascertain that the most important parts of the picture are optimally exposed, or to measure the incident light to the scene with an integrating adapter.

Visible light reflectance photometry

A reflectance photometer measures the reflectance of a surface as a function of wavelength. The surface is illuminated with white light, and the reflected light is measured after passing through a monochromator. This type of measurement has mainly practical applications, for instance in the paint industry to characterize the colour of a surface objectively.

UV and visible light transmission photometry

ABSORPTION SPECTROSCOPY

These are optical instruments for measurement of the absorption of light of a given wavelength (or a given range of wavelengths) of coloured substances in solution. From the light absorption, Beer's law makes it possible to calculate the concentration of the coloured substance in the solution. Due to its wide range of application and its reliability and robustness, the photometer has become one of the principal instruments in biochemistry and analytical chemistry. Absorption photometers for work in aqueous solution work in the ultraviolet and visible ranges, from wavelength around 240 nm up to 750 nm.

The principle of spectrophotometers and filter photometers is that (as far as possible) monochromatic light is allowed to pass through a container (cell) with optically flat windows containing the solution. It then reaches a light detector, that measures the intensity of the light compared to the intensity after passing through an identical cell with the same solvent

but without the coloured substance. From the ratio between the light intensities, knowing the capacity of the coloured substance to absorb light (the absorbency of the coloured substance, or the photon cross section area of the molecules of the coloured substance at a given wavelength), it is possible to calculate the concentration of the substance using Beer's law.

Two types of photometers are used: spectrophotometer and filter photometer. In spectrophotometers a monochromator (with prism or with grating) is used to obtain monochromatic light of one defined wavelength. In filter photometers, optical filters are used to give the monochromatic light. Spectrophotometers can thus easily be set to measure the absorbance at different wavelengths, and they can also be used to scan the spectrum of the absorbing substance. They are in this way more flexible than filter photometers, also give a higher optical purity of the analyzing light, and therefore they are preferably used for research purposes. Filter photometers are cheaper, robuster and easier to use and therefore they are used for routine analysis. Photometers for microtiter plates are filter photometers.

Infrared light transmission photometry

Spectrophotometry in infrared light is mainly used to study structure of substances, as given groups give absorption at defined wavelengths. Measurement in aqueous solution is generally not possible, as water absorbs infrared light strongly in some wavelength ranges. Therefore, infrared spectroscopy is either performed in the gaseous phase (for volatile substances) or with the substances pressed into tablets together with salts that are transparent in the infrared range. Potassium bromide (KBr) is commonly used for this purpose. The substance being tested is thoroughly mixed with specially purified KBr and pressed into a transparent tablet, that is placed in the beam of light. The analysis of the wavelength dependence is generally not done using a monochromator as it is in UV-Vis, but with the use of an interferometer. The interference pattern can be analyzed using a Fourier transform algorithm. In this way, the whole wavelength range can be analyzed simultaneously, saving time, and an interferometer is also less expensive than a monochromator. The light absorbed in the infrared region does not correspond to electronic excitation of the substance studied, but rather to different kinds of vibrational excitation. The vibrational excitations are characteristic of different groups in a molecule, that can in this way be identified. The infrared spectrum typically has very narrow absorption lines, which makes them unsuited for quantitative analysis but gives very detailed information about the molecules. The frequencies of the different modes of vibration varies with isotope, and therefore different isotopes give different peaks. This makes it possible also to study the isotopic composition of a sample with infrared spectrophotometry.

Atomic absorption photometry

Atomic absorption photometers are photometers that measure the light from a very hot flame. The solution to be analyzed is injected into the flame at a constant, known rate. Metals in the solution are present in atomic form in the flame. The monochromatic light in this type of photometer is generated by a discharge lamp where the discharge takes place in a gas with the metal to be determined. The discharge then emits light with wavelengths corresponding to the spectral lines of the metal. A filter may be used to isolate one of the main spectral lines of the

metal to be analyzed. The light is absorbed by the metal in the flame, and the absorption is used to determine the concentration of the metal in the original solution.

MICROTOME

A microtome is a precision instrument utilized for slicing ultra-thin sections of various materials, including bones, minerals, and teeth. These sections, commonly referred to as slices, are crucial for microscopic examination, enabling the preparation of samples for observation under transmitted light or electron radiation. Microtomes employ blades made of steel, glass, or diamond, chosen based on the specific specimen and desired thickness of the sections. Remarkably, microtome sections can achieve incredible thinness, allowing for slicing materials as delicate as a human hair, with section thickness ranging from 50 nanometers to 100 micrometers.

TYPES OF BLADES

1. Steel blades are used to prepare sections of animal or plant tissues for light microscopy histology.
2. Glass knives are used to slice sections for light microscopy and to slice very thin sections for electron microscopy.
3. Diamond knives are used to slice hard materials such as bone, teeth and plant matter for both light microscopy and for electron microscopy.

Types of microtomes (*Based on the mechanism*)

1. Rocking
2. Rotary Rocking
3. Sledge microtome
4. Rotary microtome
5. Cryomicrotome
6. Ultramicrotome
7. Vibrating microtome
8. Saw microtome
9. Laser microtome



1) Rocking microtome

2) **Rotary rocking microtome**



Main Types of Microtomes

- 3) Sledge microtome: Typical applications for this design of microtome are of the preparation of large samples, such as those embedded in paraffin for biological preparations. Typical cut thickness achievable on a sledge microtome is between 1 and 60 μm .



1. Rotary microtome

The typical cut thickness for a rotary microtome is between 1 and 60 μm . For hard materials, such as a sample embedded in a synthetic resin, this design of microtome can allow good "semi-thin" sections with a thickness of as low as 0.5 μm



2. Cryomicrotome

For the cutting of frozen samples, many rotary microtomes can be adapted to cut in a liquid-nitrogen chamber, in a so-called cryomicrotome setup.

The reduced temperature allows the hardness of the sample to be increased, such as by undergoing a glass transition, which allows the preparation of semi- thin samples.

However the sample temperature and the knife temperature must be controlled in order to optimise the resultant sample thickness.

3. Ultramicrotome

It allows the preparation of extremely thin sections

The typical thickness of these cuts is between 40 and 100 nm for transmission electron microscopy. Diamond knives (preferably) and glass knives are used with ultramicrotomes. To collect the sections, they are floated on top of a liquid as they are cut and are carefully picked up onto grids suitable for TEM specimen viewing.



4. Vibrating microtome

The vibrating microtome operates by cutting using a vibrating blade, allowing the resultant cut to be made with less pressure than would be required for a stationary blade.

The vibrating microtome is usually used for difficult biological samples.

The cut thickness is usually around 30–500 μm for live tissue and 10–500 μm for fixed tissue.



5. Saw microtome

- The saw microtome is especially for hard materials such as teeth or bones.
- The microtome of this type has a recessed rotating saw, which slices through the sample.
- The minimal cut thickness is approximately 30 μm and can be made for comparatively large samples.



